

Watson Capstone Project Interface for IBM 1403-N1 Printer

WCP22

Ryan Kulesza – Team Lead, Peter Haviland,
Mohammad Imran, Yuchao Wang

Supported by The Center for Technology & Innovation (CT&I)

Sponsored by IEEE Binghamton Chapter, Chair: William Tracz



ABCDEFGHIJKLMNOPQRSTUVWXYZ0123456789+- #, \$. @%*□

3

12/13/2013

Presentation Outline

- Project Goal
- History of the IBM1403-N1 Printer
- Functionality of the IBM1403-N1 Printer
- Design Solutions, Hardware and Software
- Project Schedule, Budget, and Future Plans
- Conclusion

Project Goal

- Interface a **modern PC** and the **IBM 1403-N1 printer** located at CT&I
 - ▣ Print multiple lines of meaningful text from the PC
 - ▣ Design for Expandability

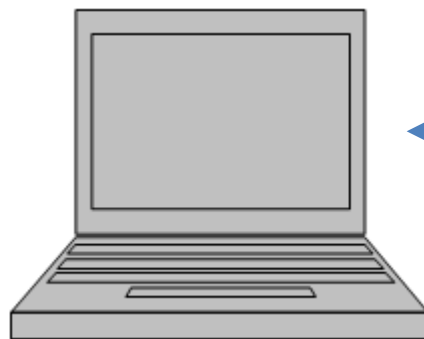

Interface



IBM 1403-N1 Printer



IBM 1403-N1 Printer History

- The IBM 1403-N1 printer was part of a successful line of affordable computing during the 1960s
 - ▣ Worked specifically with the IBM 1401 Processor

IBM 1402 Card Read-Punch

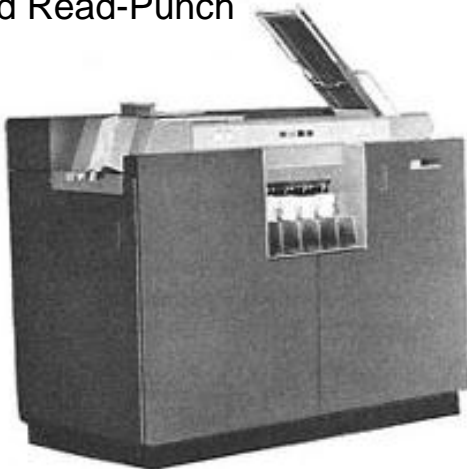

1

IBM 1401 Processing Unit

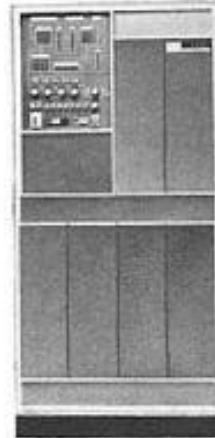

IBM 1403-N1 Printer



IBM 1403-N1 Printer Functionality

- The printer utilizes a **character belt** and **printer hammers**

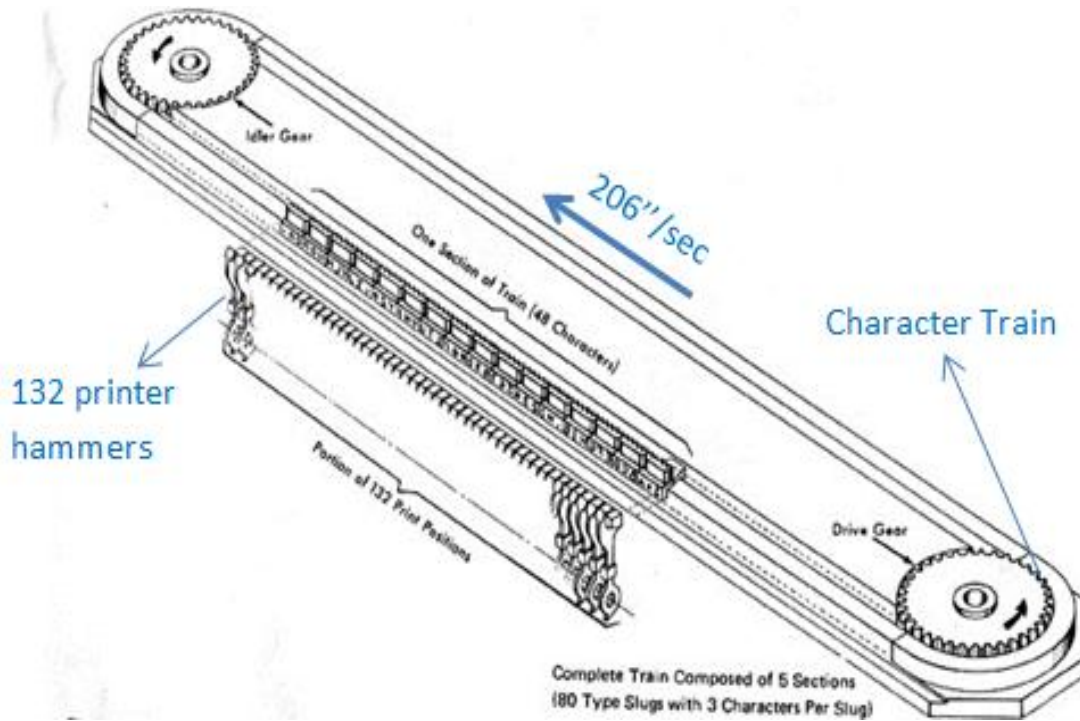

Printer Hammers

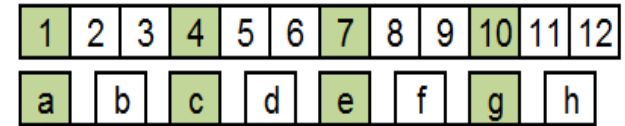

Character Belt

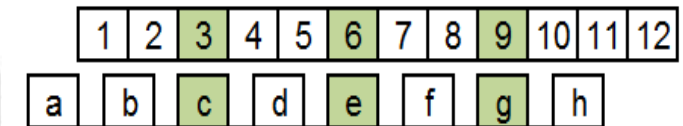
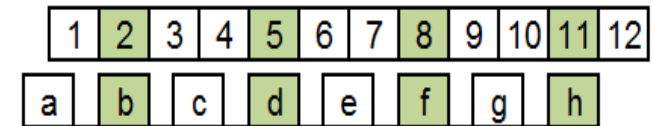

IBM 1403-N1 Carriage Functionality

- Carriage moves the paper up, enters on your PC.
- 1403-N1 utilizes mechanical hydraulic units for carriage control.
- Four units control space start, space stop, skip start and skip stop magnets.
- Gears in hydraulic units sends out signals as spacing being carried out.
- Skipping is just spacing multiple lines.

IBM 1403-N1 Driver Cards

- The printer uses driver cards to control the **printer hammers** and **carriage**
 - ▣ Utilizes Standard Modular System (SMS) technology
 - ▣ Hardware currently unavailable



Contextual Flow Chart

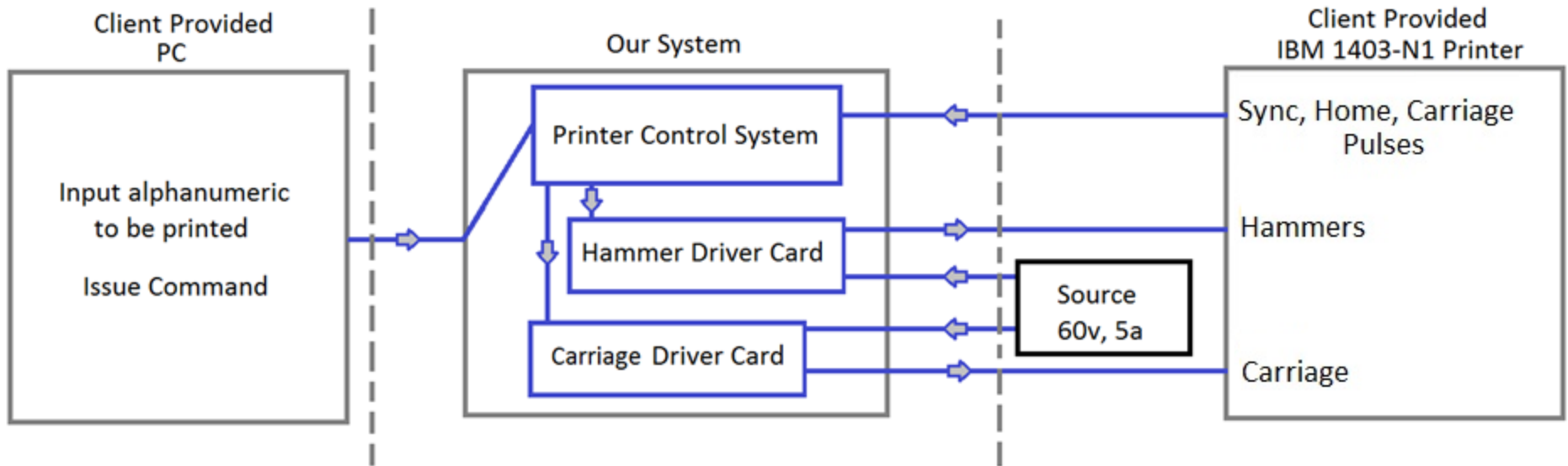

System Block Diagram

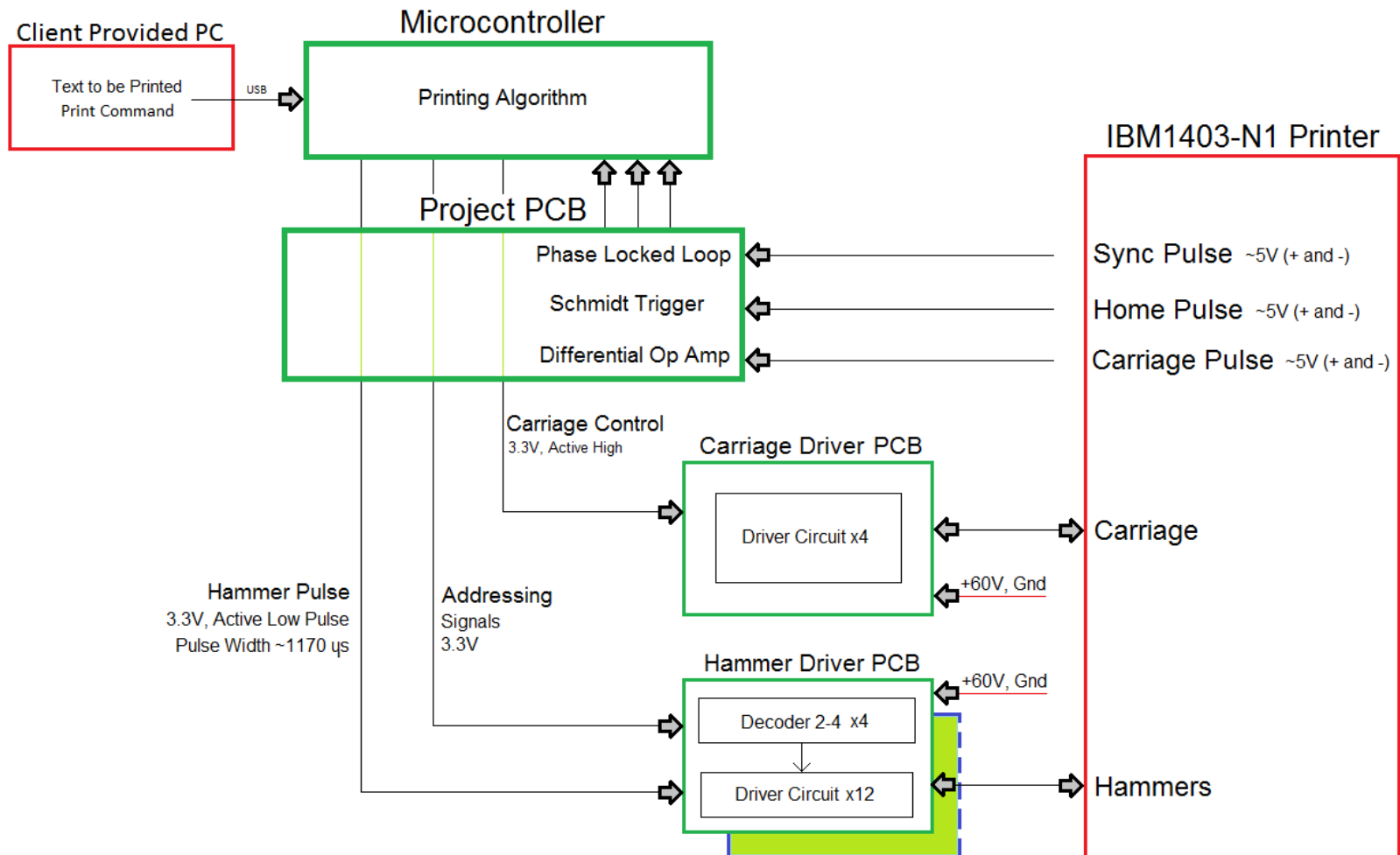

System Microcontroller Trade Study

Criterion	Weight	Arduino Due			chipKIT Pro MX4		
		Value	Score	Result	Value	Score	Result
# of I/O Pins	.2	54	2	0.4	74	5	1
Pin Voltage	.1	3.3V	4	0.4	3.3V	4	0.4
I/O Total Current	0.05	130 mA	4	0.2	200 mA	5	0.25
Input Voltage	0.05	7-12V	5	0.25	3.6-12V	5	0.25
Clock Speed	0.2	84 MHz	5	1	80 MHz	5	1
Flash Memory	0.2	512 kB	5	1	512 kB	5	1
SRAM	0.05	96 kB	5	0.25	32 kB	3	0.15
EEPROM	0.05	N/A	0	0	N/A	0	0
Cost	0.1	\$58	3	0.3	\$80	2	0.2
Sum	1			3.8			4.25

Printing Algorithm

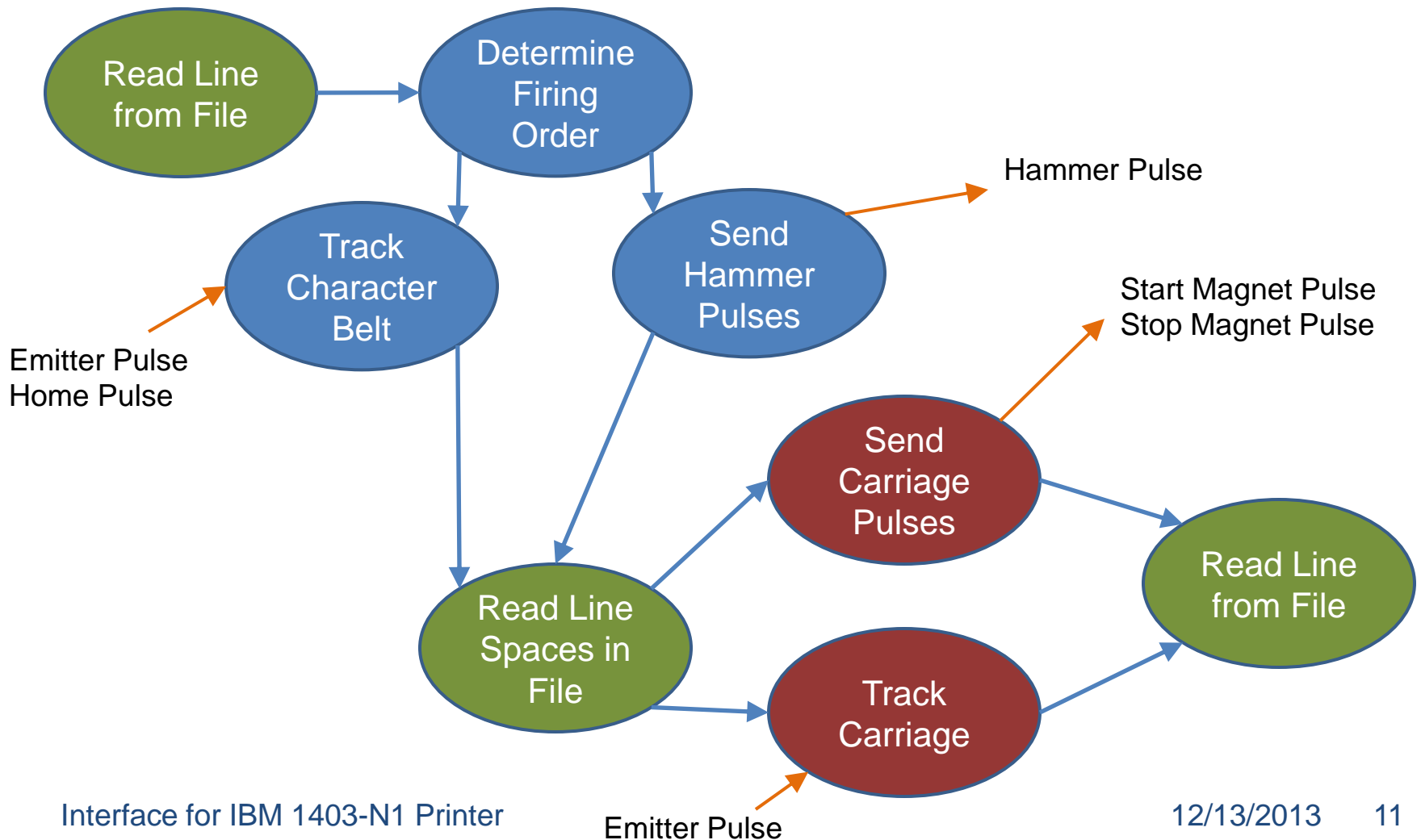

Schedule

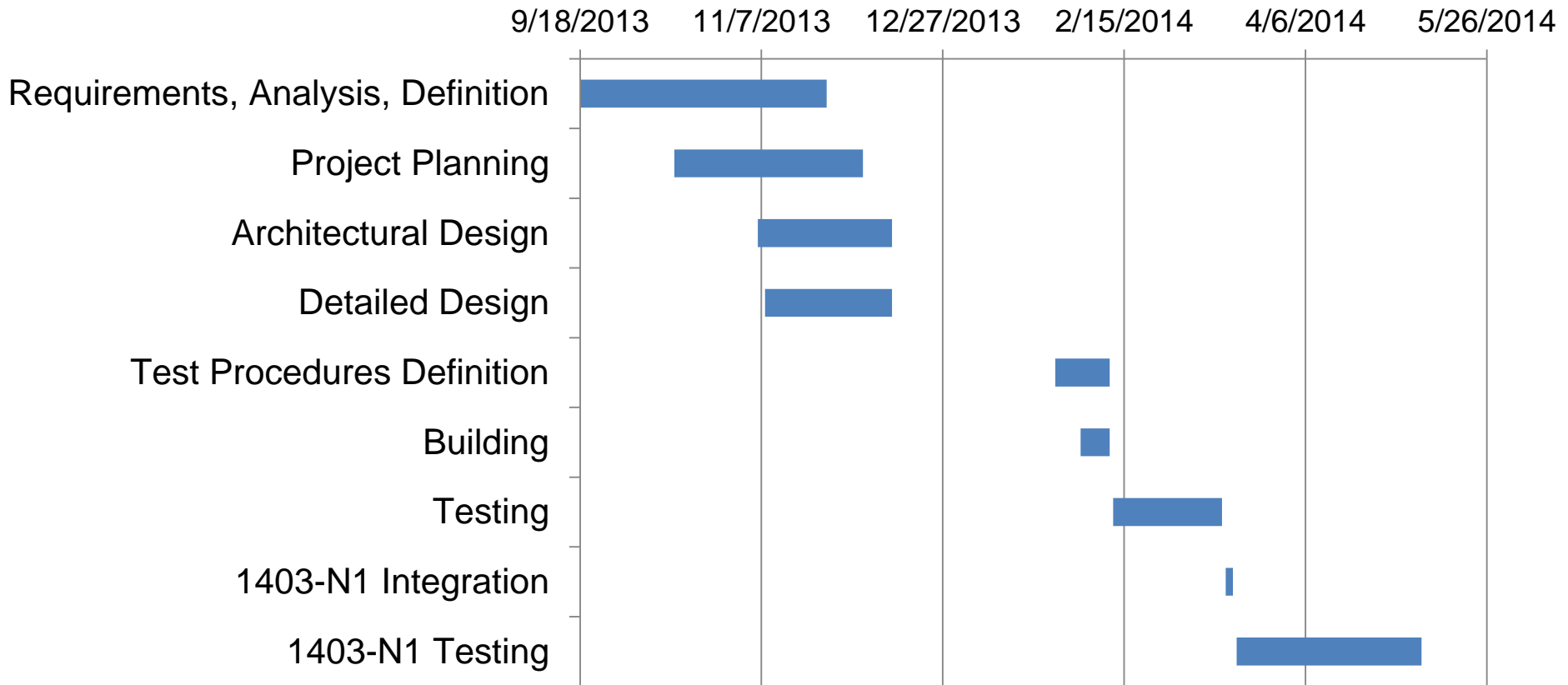

Team Budget

Item	Original Estimate	Expended	Estimate-to-Completion	Estimate-at-Completion
Electrical Components	75	0	175	175
Printed Circuit Boards	75	0	175	175
Microcontroller	50	0	80	80
Expandable Memory	30	0	30	30
Cables	20	0	20	20
				Total: \$480
Sponsored by IEEE Binghamton Chapter			Manageable Budget: \$1600	

Future Plans

- Ordering, Population, Unit Testing, and Integration of Printed Circuit Boards
- Testing of Algorithm and Integration of microcontroller
- Integration and Testing of Printer Interface Project and IBM1403-N1 Printer
- Completing Documentation for Use, Maintenance, and Expansion
- Optional incorporation of additional print functions (bold text, block letters)

Conclusion





Special Thanks To...

IEEE Binghamton

The Center For Technology & Innovation

Professor Jack Maynard

Interface for IBM 1403-N1 Printer

12/13/2013

Image References

1. http://www-03.ibm.com/ibm/history/ibm100/images/icp/R709458M58603Y15/us__en_us__ibm100__1401__minimal_system__620x350.jpg
 2. <http://www.beagle-ears.com/lars/engineer/comphist/c20-1684/fig011.jpg>
 3. <http://ibm-1401.info/1403Font-.jpg>
 4. <http://ibm-1401.info/SMS-AEN-.jpg>
 5. <http://content.answcdn.com/main/content/img/CDE/BANDPRNT.GIF>
- Team Photo: Center for Technology & Innovation, 2013
 - Special Thanks Graphic: “Hammer Driver PCB Layout,” by Yuchao Wang